

Installation Manual Book



JX-T05D

Installation Step 1:

Photo1 :

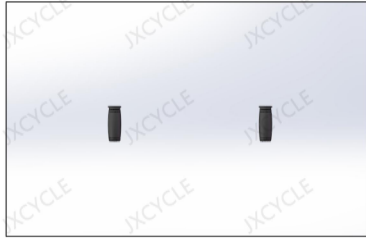

Photo1 : Anti collision handle cover
Size:inside diameter 22.2mm*100mm

Photo2:

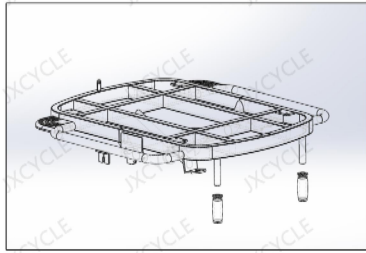

Photo2: Install the anti-collision handle cover on the front underframe limit bar

www.ixcycle.com

Installation Step 2:

Photo1 :



Photo1 : Put screws to front mud guard,
Size:M6*40mm
Put nut,size M6

Photo2: Fix screws to front mud guard,
Size: M6*40mm
Put nut, size M6

Photo3: Put mud guard into front bottom as Photo3

Photo2:



Photo3:

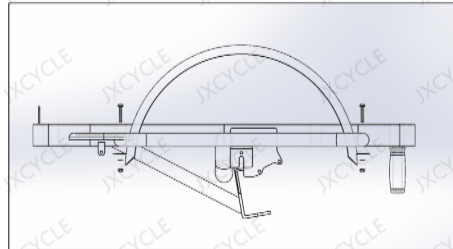

www.ixcycle.com

Installation3:

Left Brake disc

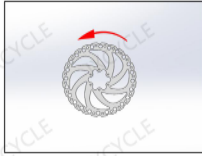

Photo1:

Right Brake disc

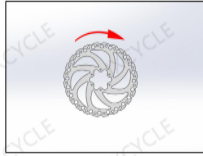

Photo1: Brake disc, size:inside diameter:160mm

Photo2: Front wheel set, size20*1.95

Photo3: Brake disc screws, sizeM5*7.5

Photo4: Photo1 shows same size of brake disc, please note they are left and right,as photo1/photo4 shows

Left front wheel

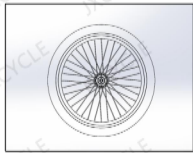

Photo2:

Right front wheel

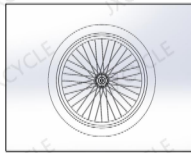

Photo3:



Left front wheel

Photo4:

Right front wheel

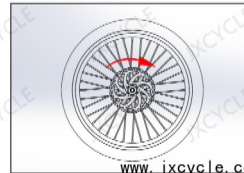
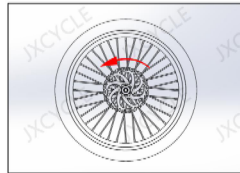

www.jxcycle.com

Installation 4:

Photo1:



Photo1: Screws for front wheel, size: M10

Safety hook, inner hole diameter11mm

Photo2:

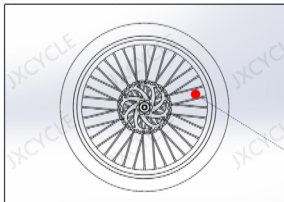

Left front wheel

Photo2: Installed front wheel set

Photo3: Install the front wheel set on the front underframe, Installation method of nut and safety hook as photo3

Photo3:

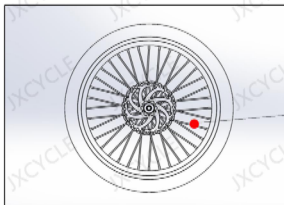

Right front wheel

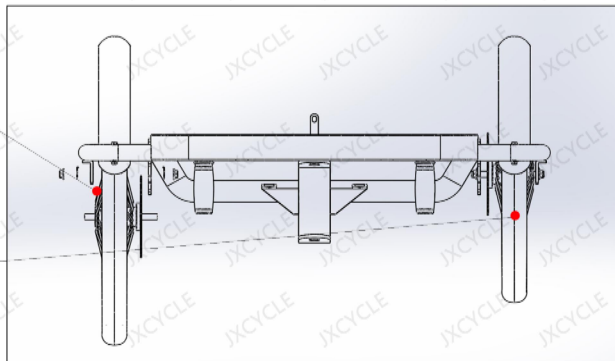

www.jxcycle.com

Installation 5:

Photo1:



Photo1: Screws for front mud guard, Size: M6*16mm
nut for screw, size M6

Photo2: Front light

Photo3: Install the headlamp on the front underframe,
same as photo3

Photo2:

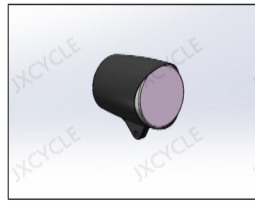
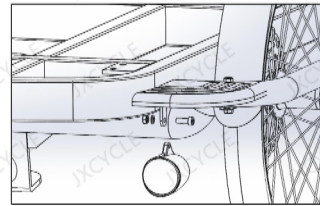

Photo3:



www.jxcycle.com

Installation 6:

Photo1:

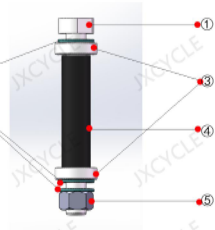

Photo1: 1 Steering connecting shaft, 2 Pad, 3 Bearing,
4 Bushing sleeve 5 M20 Nut

Photo2: First, install the bearing in the rear frame head pipe
as shown in the photo

Photo3: Finished Installation of steering connecting shaft
as photo 3, photo 1, photo 2.

Photo4: If finished installation, Same as photo 4

Photo2:

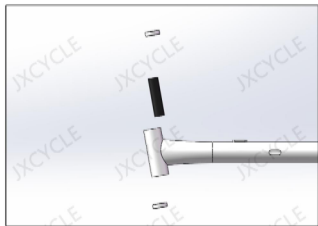

Photo3:

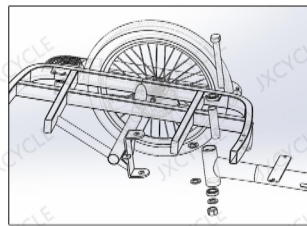
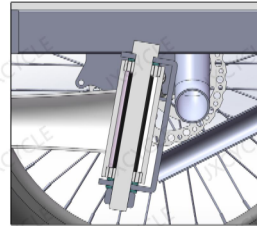

Photo4:



www.jxcycle.com

Installation 7:

Photo1:

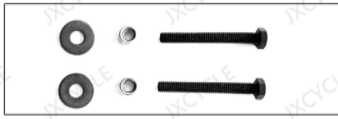

Photo1: Front mud guard screw, size: M8*65mm nut, sizeM8

Photo2: Handlebar assembly sets

Photo2:

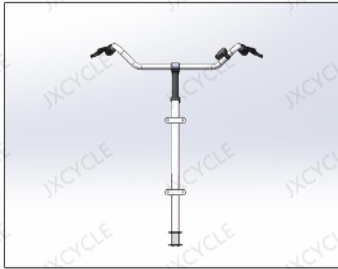
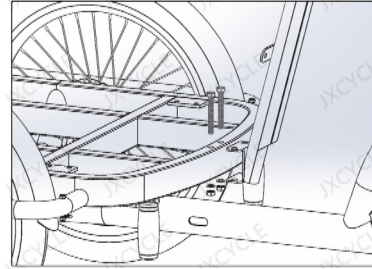

Photo3: The handlebar is installed on the hole behind the front underframe, same as photo 3

Photo3:



www.jxcycle.com

Installation 8:

Photo1:



Photo1: Damper, Size: 340mm*120mm*150N

Photo2: Damper'screw, Size: nutM8

Photo2:

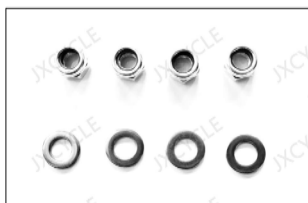
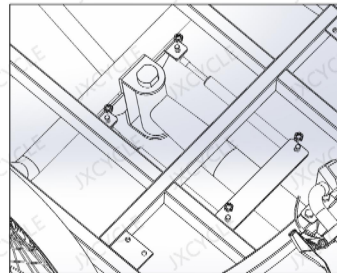

Photo3: Install the damper on the fixing plate of the front underframe and the rear frame, as photo3

Photo3:



www.jxcycle.com

Installation 9:

Photo1:



Photo1: Fixing screw of disc brake clamp of front wheel group, size: M6*16

Photo2: Left and right clamps, as photo 2 shows

Photo3: Install the clamp on the front bottom.

The left side of the bracket and the right side clamp are installed on the right side.

Same as photo 3 and photo 4.

Photo2:

Left clamp Right clamp



Photo3:

Left Clamp



Photo4:

Right clamp



www.jxcycle.com

Installation10:

Photo1:

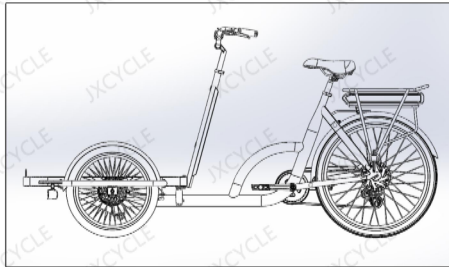

Photo1: After the front underframe and the rear frame are assembled, the test shall be carried out.

Test content first spot: Is the left and right brake force of the front brake the same.

Test content second spot: Is the transmission normal.

Test content third spot: Is the electronic control system working properly (Is the headlight on normal operation, whether the motor works normally, whether the pedal assist works normally, and whether the brake handle is broken Whether it works normally.)

Noted: If the above problems occur, please detect the cause of the failure and carry out troubleshooting.

Replace the accessories. When there is no problem with the above points, the wooden box can be assembled.

www.jxcycle.com

Installation11:

Photo1:

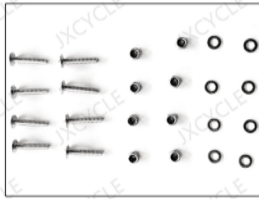
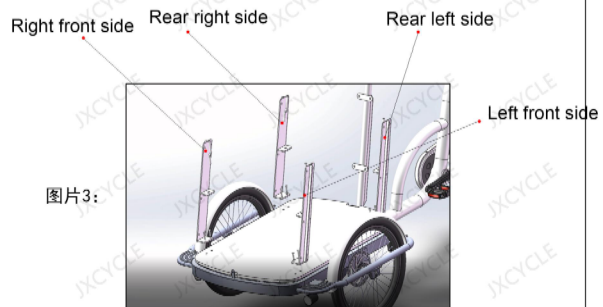

Photo1: Front wheel set disc brake clamp screws, size: M6*30, nutM6

Photo2: T-piece of wooden box is divided into front, back, left and right

Photo3: The installation and fixing position of T-piece of wooden box is divided into front, back, left and right. Combined with picture 2 and picture 3. Install according to the corresponding position.

Photo2:



www.ixcycle.com

Installation12:

Photo1:



Photo1: Rear seat panel fixing

Photo2: Rear baffle fixing screw, size: M6*30, Nut: M6

Photo3: Mounting position of fixing plate, as Photo 3

Photo2:



Photo3:

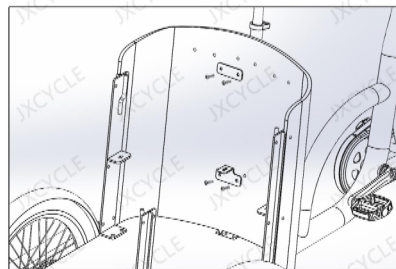

www.ixcycle.com

Installation13:

Photo1:

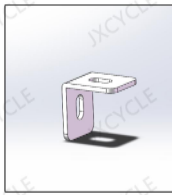

Photo1: Front seat plate fastener

Photo2: Front baffle fixing screw, size: M6*25, nut: M6

Photo3: Mounting position of fixing plate as Photo3

Photo2:



Photo3:

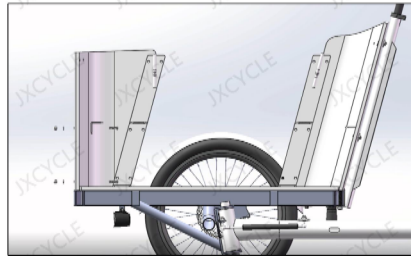

www.jxcycle.com

Installation14:

Photo1:

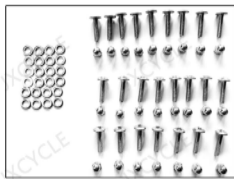
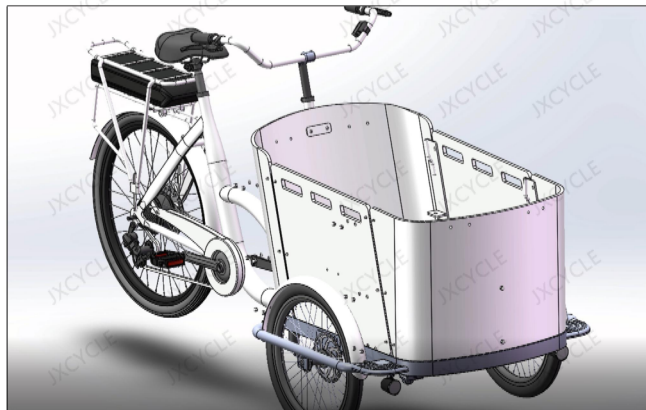

Photo1: Wooden box side plate fixing screw, size M6*25, nut M6

Photo2: The screw is fixed on the angle iron hole of the wooden box, and the screw is fixed from the inside to the outside, Add gasket on the outside of the wooden box, and finally screw the nut. A total of 24 screws

Photo2:



www.jxcycle.com

Installation15:

Photo1:

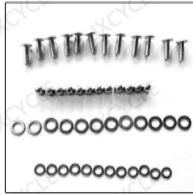

Photo2:



Photo1: Wooden box side plate fixing screw, sizeM6*25、NutM6

Photo2: Safety belt

Photo3: Red is the seat belt pre assembly hole,
yellow is the front and rear seat plate pre assembly hole

Photo: Install as shown in picture 4

Safety belt fixing hole

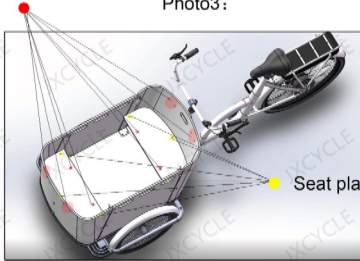

Photo3:

Seat plate fixing hole

Photo4:



www.ixcycle.com

Installation16:

Photo1:



Photo2:



Photo1: Rear seat panel baffle lock

Photo2: Rear seat panel baffle hinge

Photo3: Place the baffle plate on the operation platform with
the hole in the upper right corner to install the lock

Photo4: The baffle is installed as shown in picture 4.

Photo4: The baffle is installed as shown in picture 4.
Rear seat panel baffle inner side: The key hole is in the upper left corner, and the red area is an
door hinge area.

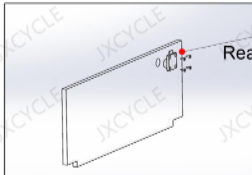

Photo3:

Photo5:



Photo4:

www.ixcycle.com

Installation17:



Photo1 :

Photo1: Wooden box pedal

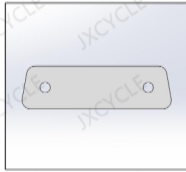

Photo2:

Photo2: Inner baffle of wooden case pedal



Photo3:

Photo3: Fixing screw of wooden box pedal, sizeM6*30

Photo4: The wooden case pedal is installed on the side plate of the wooden case, and the installation method is shown in Photo 4

Photo4:



www.ixcycle.com

Installation18:



Completion of assembly: before the test ride, charge the battery first, and the tire pressure is normal before you can ride.

www.ixcycle.com

